

UNIVERSAL GAS VALVES VR400/VR800 SERIES

CLASS "A" SERVO REGULATED COMBINATION VALVES

PRODUCT HANDBOOK

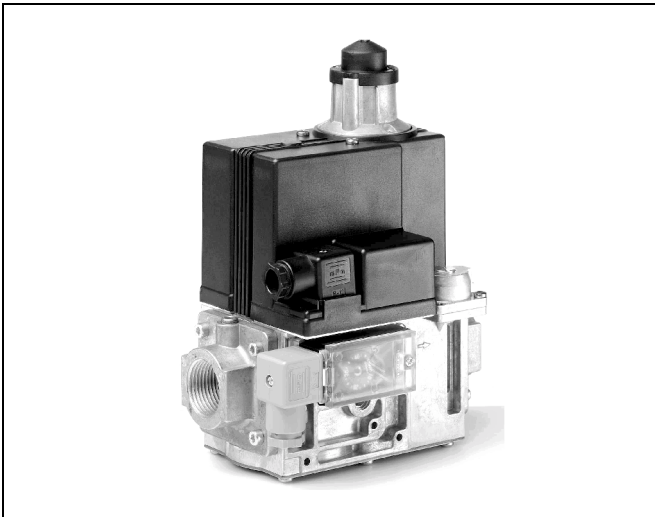

APPLICATION

The VR400 Series class "A" servo regulated combination valves are used for control and regulation of gaseous fuels in gas fired power burners, atmospheric gas boilers, melting furnaces, incinerators and other gas consuming appliances.

These servo regulated combination valves are available in Three different versions:

- VR415/VR815 (pipe sizes 1/2")
- VR420/VR820 (pipe sizes 3/4")
- VR425/VR825 (pipe sizes 1")
- VR432/VR832 (pipe sizes 1 1/4")

Contents

General

Description	2
Features	3

Technical

Specifications	4
Performance Characteristics	5
Capacity curves	6 - 9
Dimensional drawings	10 - 11

Installation and Operation

Installation	12
Adjustments and final checkout	13
construction and working principles	15

Various

Standards and approvals	16
ordering information	17
Replacement parts and accessories	21

DESCRIPTION

The VR400/VR800 series class "A" servo regulated combination valves are suitable for the control of gaseous fuels in gas consuming appliances according to international standards.

The VR400/VR800 series meet the class A + A specification according EN 161.

The VR400/VR800 series have 1/2, "3/4", 1" and 1¼" straight flanged pipe connection .

The VR400/VR800 series are standard equipped with two main valves V1 and V2.

Safety valve V1 is always fast opening/closing.
The second valve (V2) can be either fast (with flow regulation) or slow (= with flow regulation and adjustable opening). The pressure regulating valve is located between V1 and V2.

The VR400/VR800 series are available for **Direct Burner Ignition (DBI)** and **Intermittent Pilot (IP)** applications.

At both sides of the main body 4 flange connections are provided to mount either an:

- inlet pressure switch C60VR serie
- interim pressure switch C60VR serie
- Valve Proving System (VPS) + pressure switch.

These accessories can be mounted on various positions of the main body of the VR400/VR800 series.

FEATURES

- Class “A” servo regulated combination valve for control of gaseous fuels in gas consuming appliances in accordance with international standards.
- Main body with two shut-off valves with single seat.
- Options for mounting flanged minimum and/or interim pressure switches.
- Valve Proving System (VPS).
- Closing time: < 1 second.
- Coils field replaceable.
- Coils suitable for permanent energization.
- Fine mesh screen (strainer) between inlet flange and main body.
- Various pressure tap points at main body available, when no additional valves or pressure switches are used.
- Second main valve, either with fast opening, or characterized opening mechanism (slow) with adjustable maximum flow rate and step pressure.
- Rectifier boards field replaceable.
- Plug connector according to DIN 43650.
- All adjustments are located on the top of the valve.
- Different pressure ranges.
- Suitable for electric modulation.
- Suitable for electric two stage regulator.
- Suitable for gas/air modulation.
- Connections for IP application.

SPECIFICATIONS

The specifications described in this chapter are related to the main gas valve (see also Performance Characteristics on page 5.). The VR400/VR800 series must be used in combination with a burner programmer.

Models

VR415/VR815 (DN15)
 VR420/VR820 (DN20)
 VR425/VR825 (DN25)
 VR432/VR832 (DN32)

Optional: adjustable opening characteristics, page 13.

For detailed regulator specifications of models with **suffix M**, **suffix F**, **suffix P** or **suffix V** see the appropriate Product Handbook.

VR4xxFy: EN1C-0001
 VR4xxMy: EN2R-9009
 VR4xxPy: EN2R-9010
 VR4xxVy: EN2R-9017

Dimensions

See dimensional drawings and table on page 11

Pipe sizes

Inlet and outlet straight flange connection: 1/2", 3/4", 1" and 1 1/4".

(all internal pipe thread according to ISO 7-1)

Capacity

See capacity curves on page 6, 7, and 8

Minimum regulating capacity

VR415/VR815: 1 m³/hr.
 VR420/VR820: 1 m³/hr.
 VR425/VR825: 1.5 m³/hr.
 VR432/VR832: 1.5 m³/hr.

Maximum operating pressure

VR400XX1000 series: 200 mbar
 VR400XX4000 series: 360 mbar
 VR800XX series: 100 mbar
 VR432/VR832 series: 100 mbar

Connections (see fig. 15. and 16.)

- 1/8" pressure taps at inlet and outlet flanges. At the main body 8 flange connections are provided to mount either an:
 - pressure switches (min. or max.)
 - Valve Proving System (VPS).
- Two 1/8" connections for IP applications.

Torsion and bending stress

Pipe connections meet group 2 according to EN 161 requirements.

Valve Classification

Class A + A according EN 126/EN 161

Regulator Classification

Class C according EN 126/EN 88

Supply voltages

Line voltage: 230 Vac, 50/60 Hz
 Other voltages on request.

Electrical equipment

DC current coils with combined rectifier inside the cover.

Electrical connections

Standard DIN plug connector

Ambient temperature range

-15 ... 60 °C

Coil insulation solenoid valves

Insulation material according class F.

Enclosure

IP 54

Body material

Aluminium alloy die cast

Strainer

Fine mesh screen (diameter 0.34 mm), AISI 303 steel, serviceable after removing inlet flange screws.
 Meets requirements for strainer according EN 161.

Closing spring

AISI 302 steel

Valve plunger

Coated Fe 360

Seals and gaskets

Hydrocarbon resistant NBR and Viton rubber types.

Flange kit

The kit consist of:

- 1 flange with sealing plug,
- 1 "O"-ring and 4 screws.
- 1 pressure tap nipple fitted

Table 1: Flange kits

O.S. number	Size (Rp)	Remarks
KTCOMB15	1/2"	with plug
KTCOMB20	3/4"	with plug
KTCOMB25	1"	with plug
KTCOMB32	1 1/4"	with plug

Table 2: Power consumption (W) VR400/VR800 series

Model	voltage	V1		V2	
		W	mA	W	mA
VRx15/VRx20	230	15.4	84	15.4	84
	110	14.6	170	14.6	170
	24	15	780	15	780
VRx25/VRx32	230	18.6	100	18.6	100
	110	22.1	250	22.1	250
	24	15.5	810	15.5	810

PERFORMANCE CHARACTERISTICS

Opening time

Dead time maximum 1 second.

The first valve (V1) opens in less than 1 second.

The second valve (V2) can be either a fast opening valve which reaches 50% of the adjustable outlet pressure within 50 sec. after start flow or a characterized opening valve which is adjustable from 1 up to 30 seconds, at rated capacity.

The opening characteristic is factory set at approximately 6 seconds at the following conditions:

- measured at 80 % of rated capacity
- 30 mbar supply pressure
- nominal voltage
- 20°C
- 2.5 mbar pressure drop
- no step pressure

Due to the influence of ambient temperature (-15 ... 60°C) the adjusted opening time of 6 seconds measured at 80% of adjusted flow rate can vary ± 4 seconds.

Maximum allowable leakage

Each VR400 combination valve has been factory tested to meet the following leakage requirements:

- outerwall: 50 cm.³/h at test pressure of 6 and 540 mbar.
- safety valve: 40 cm.³/h at test pressure of 6 and 540 mbar.
- main valve : 40 cm.³/h at test pressure of 6 and 540 mbar.

High pressure test

In the "OFF" condition, the VR400 valve will withstand 1.5 bar (air) inlet pressure without damage.

Attempts to operate the VR400, while in this condition, will not cause damage.

Oscillation

Maximum oscillation under all circumstances p 0.5 mbar.

Tap sensitivity of outlet pressure set point

For all gases the maximum deviation may be 1 mbar.

Repeatability of outlet pressure set point

For all gases the maximum deviation from set point is ± 0.3 mbar or + 3% of the set point value, whichever is the greatest.

Table 3: Total set point shift

Pressure range (mbar)	Tolerance
3 ... 37	6% of the set point value or 1 mbar whichever is the greatest
2 ... 20 *	6% of the set point value or 1 mbar whichever is the greatest
8 ... 50	6% of the set point value or 2.2 mbar whichever is the greatest

* 2 ... 20 mbar regulation not to be specified on valves with 360 mbar inlet pressure.

Closing time (V1, V2)

Less than 1 second for all valves.

Maximum working frequency

1 cycle per minute

Duty cycle

Coil suitable for permanent energization in cooperation with ignition controller

Operational voltage range

The combination gas valve will function satisfactory between 85% and 110% of the rated voltage.

Table 4: Design life

Model	Number of cycles
VR415/VR815	500,000
VR420/VR820	
VR425/VR825	
VR432/VR832	

CAPACITY CURVES AND RECOMMENDED WORKING AREA

Capacity curves servo regulated combination gas valves

Table 5: Capacity

1/2" DN15
6 m ³ /h air at Δp = 5 mbar

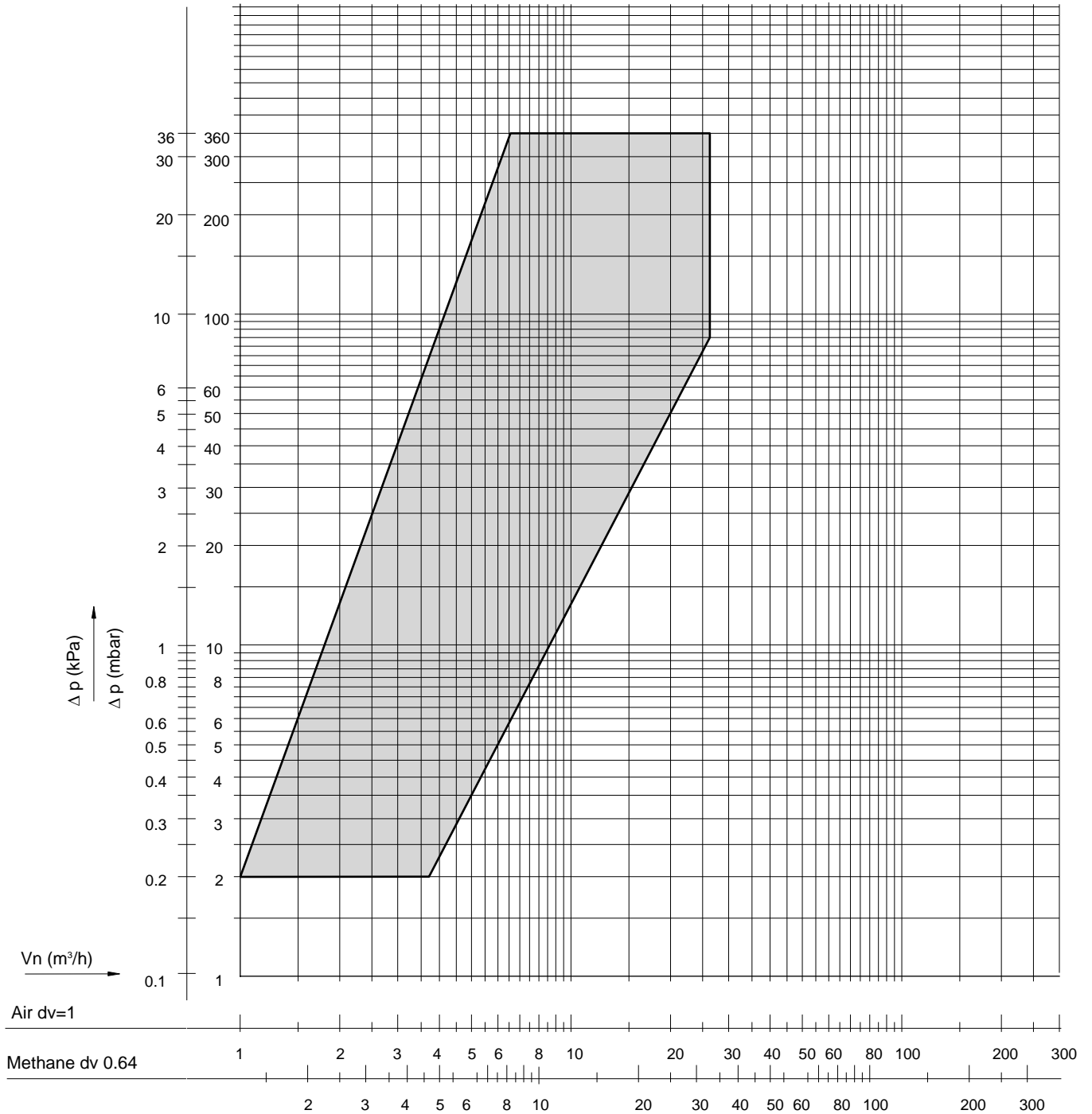

Fig. 1. Capacity curves for VR415/VR815 series (DN15)

CAPACITY CURVES AND RECOMMENDED WORKING AREA

Capacity curves servo regulated combination gas valves

Table 6: Capacity

3/4" DN20
9 m ³ /h air at Δp = 5 mbar

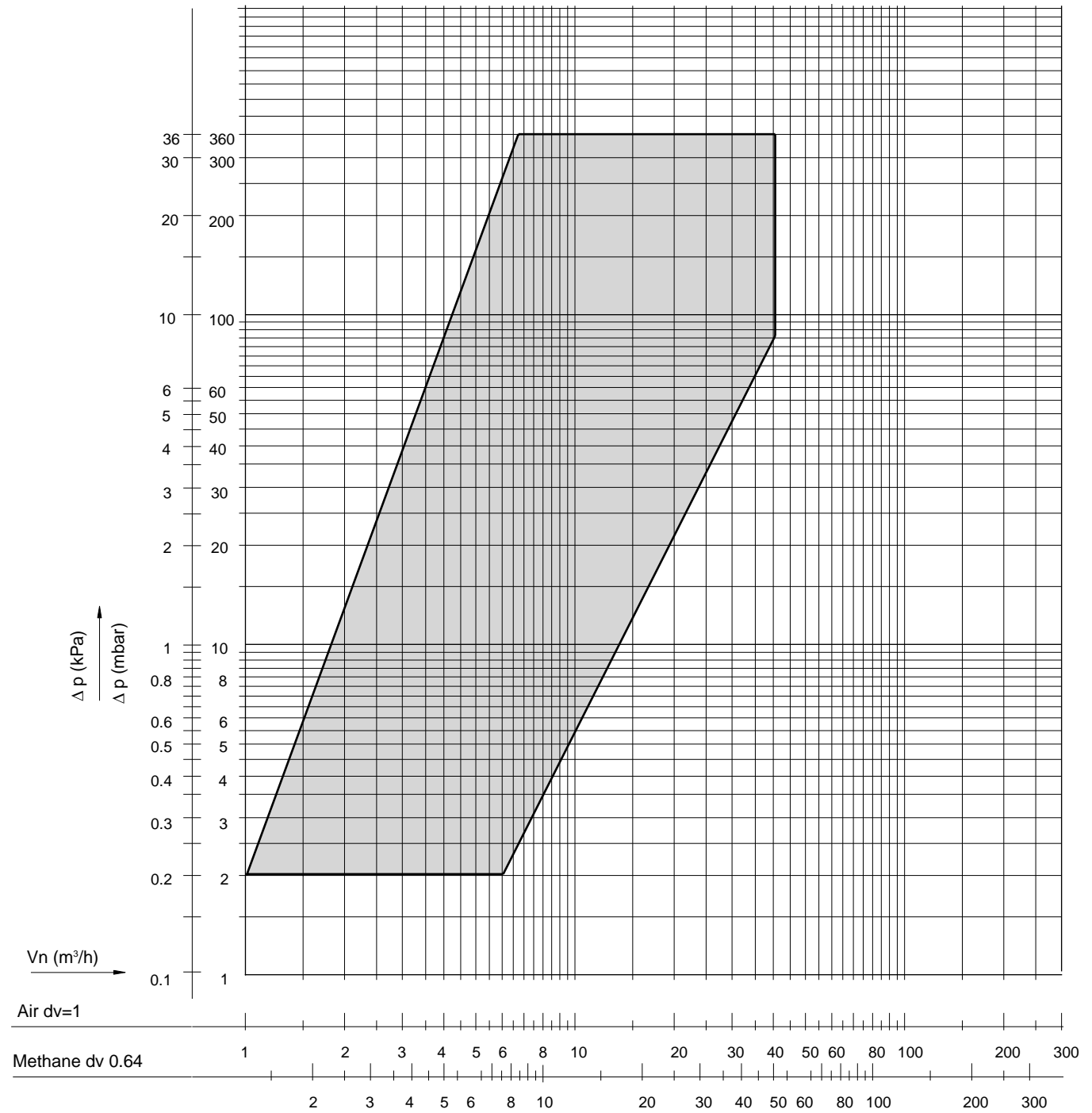

Fig. 2. Capacity curves for VR420/VR820 series (DN20)

CAPACITY CURVES AND RECOMMENDED WORKING AREA

Capacity curves servo regulated combination gas valves

Table 7: Capacity

1" DN25
13 m ³ /h air at $\Delta p = 5$ mbar

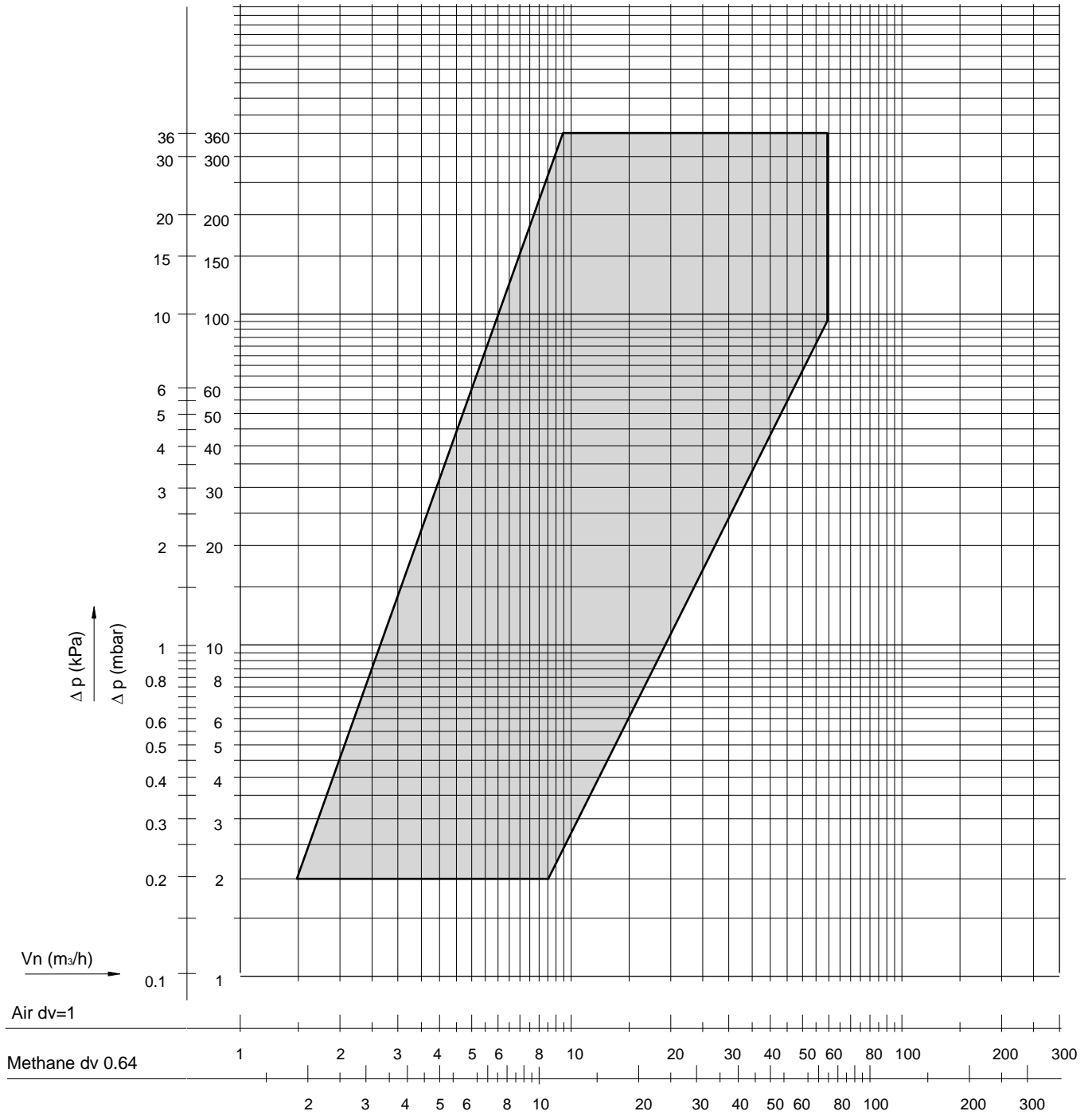

Fig. 3. Capacity curves for VR425/VR825 series (DN25)

CAPACITY CURVES AND RECOMMENDED WORKING AREA

Capacity curves servo regulated combination gas valves

Table 8: Capacity

1" DN32
14.5 m ³ /h air at $\Delta p = 5$ mbar

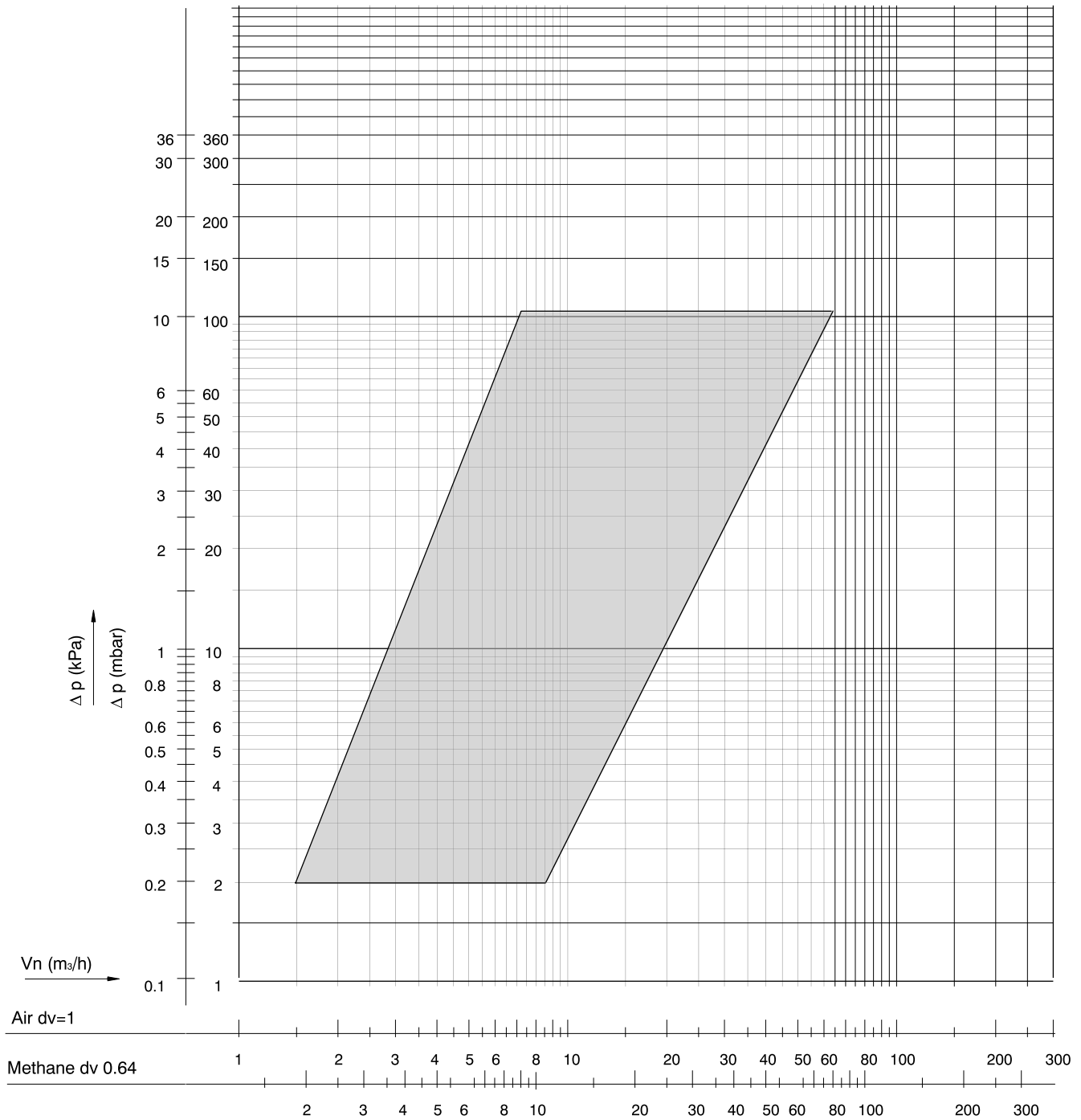

Fig. 4. Capacity curves for VR432/VR832 series (DN32)

DIMENSIONAL DRAWINGS VR415/VR815 AND VR420/VR820

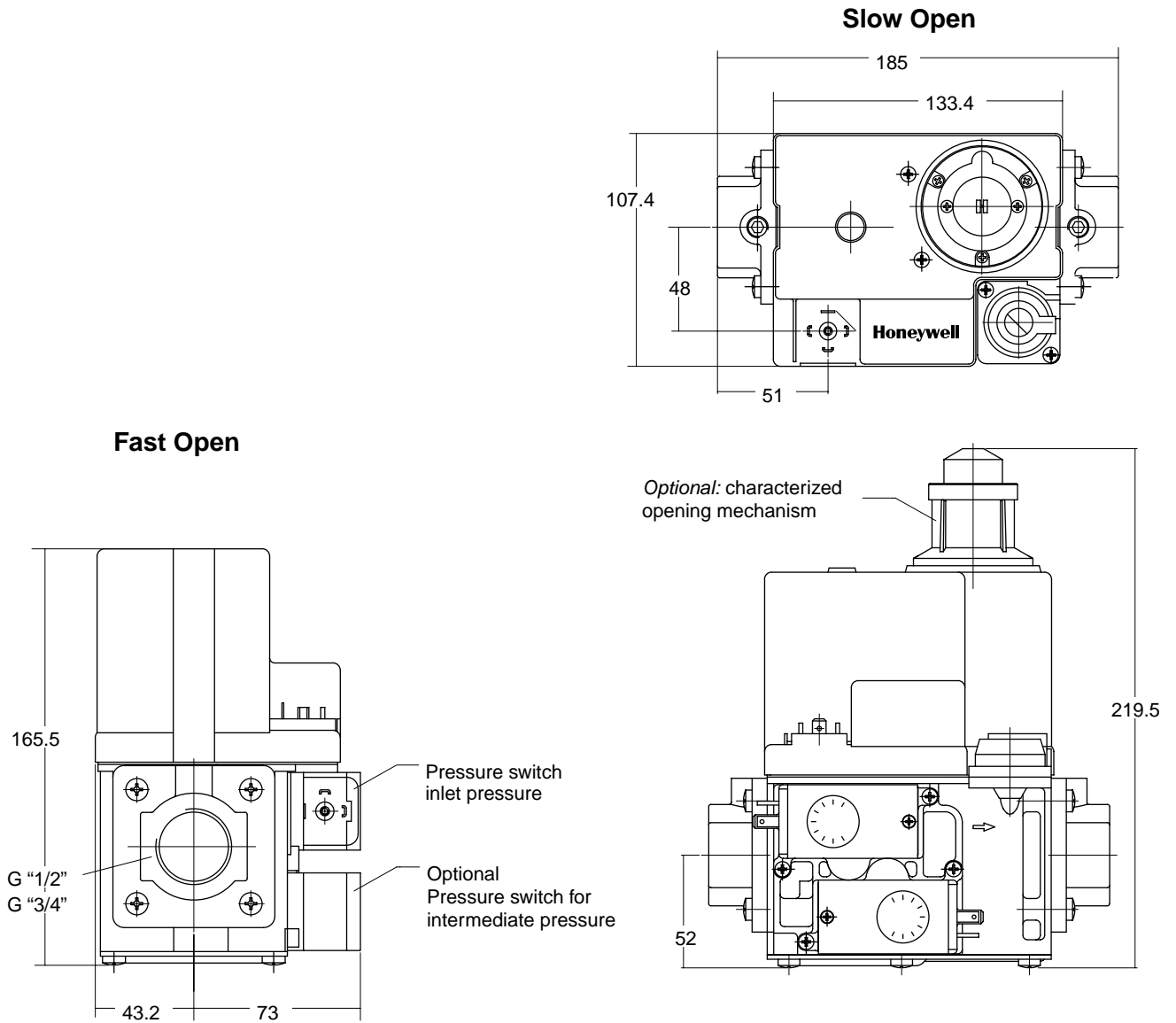
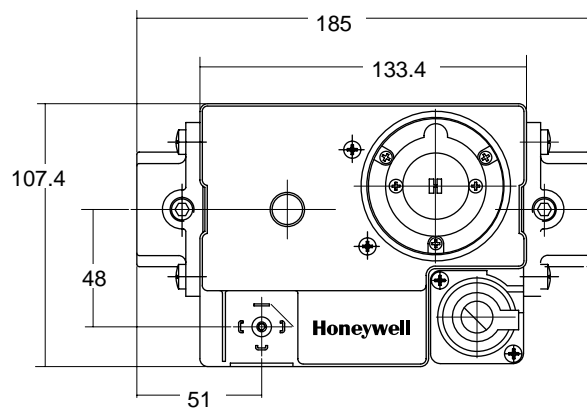

Fig. 5. Dimensional drawing VR415/VR815 (DN15) and VR420/VR820 series (DN20)

DIMENSIONAL DRAWINGS VR425/VR825/VR432/VR832

Slow Open



Fast Open

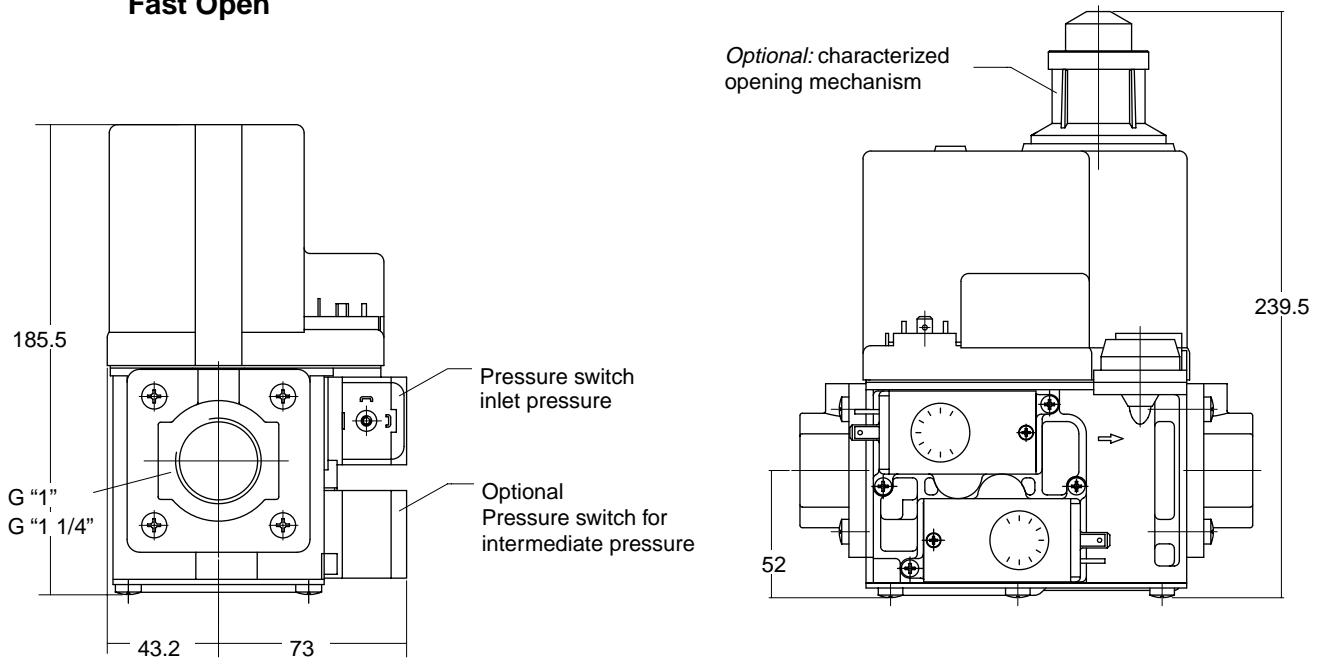

Fig. 6. Dimensional drawing VR425/VR825 series (DN25) and VR432/VR832 series (DN32)

INSTALLATION

IMPORTANT

Read these instructions carefully. Failure to follow the instructions could damage the product or cause a hazardous condition.

Check the ratings given in the instructions and on the product to make sure the product is suitable for your application.

The installation has to be carried out by qualified personnel only.

Carry out a thorough checkout when installation is completed.

CAUTION

- Turn off gas supply before installation.
- Disconnect power supply to the valve actuator before beginning the installation to prevent electrical shock and damage to the equipment.
- Do not remove the seal over valve inlet and outlet, until ready to connect piping.
- The valve must be installed so that the arrow on the valve points in the direction of the gas flow (gas pressure helps to close the valve).

Mounting position

The gas valve can be mounted plus or minus 90 degrees from the vertical.

Mounting location

The distance between the gas valve and the wall/ground, must be at least 30 cm.

Main gas connection

1. Take care that dirt does not enter the gas valve during handling
2. Remove the flanges from the valve.
3. Use a sound taper fitting with thread according to ISO 7-1 or new, properly reamed pipe free from swarf.
4. Apply a moderate amount of good quality thread compound to the pipe for fitting only, leaving the two end threads bare, PTFE tape may be used as an alternative.
5. Screw the flanges onto the pipes.
6. Ensure that the inlet and outlet flanges are in line and separate from each other enough to allow the valve to be mounted between the flanges without damaging the "O"-ring.
7. Place the "O"-ring. If necessary grease it slightly to keep it in place.
8. Mount the gas valve between the flanges using the bolts for each flange.
9. Complete the electrical connections as instructed in the Electrical Connection section.

WARNING

Tightness test after installation

- Spray all pipe connections and gaskets with a good quality gas leak detection spray.
- Start the appliance and check for bubbles. If a leak is found in a pipe connection, remake the joint. A gasket leak can usually be stopped by tightening the mounting screws, otherwise, replace the gas

valve.

Electrical connection

CAUTION

- Switch off power supply before making electrical connections.
- All wiring must comply with local codes, ordinances and regulations.

Use lead wire which can withstand 105 °C ambient.

Wiring

Follow the instructions supplied by the appliance manufacturer. Refer to fig. 7. and fig. 8.

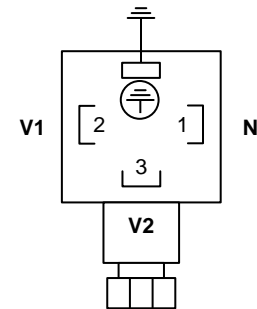

Fig. 7. Three pin electrical plug connector (according to ISO 4400) for IP applications.

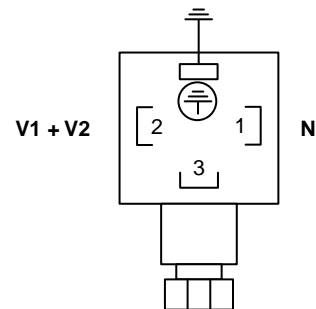

Fig. 8. Three pin electrical plug connector (according to ISO 4400) for DBI applications.

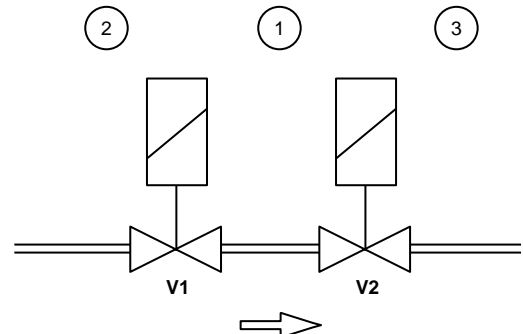

Fig. 9. Connection diagram VR400

ADJUSTMENTS AND FINAL CHECKOUT

The procedures described in this chapter are related to the adjustments on the main gas valve. For adjustments on the other additional functionalities (e.g. pressure switch), refer to the included instruction sheet of the product in question in the package.

WARNING

Adjustments must be made by qualified personnel only.
To ensure a safe closing of the valves, it is essential that voltage over the terminals of operators is reduced to 0 Volts.

2nd valve fast opening

The following characteristics can be adjusted:

- flow rate

Flow rate adjustment

1. Remove the cap from the cover.
2. Turn adjustment screw counter-clockwise to increase or clockwise to decrease the flow rate.

2nd valve (slow opening)

The following characteristics can be adjusted:

- flow rate
- step pressure

IMPORTANT

To ensure a satisfactory setting of the valve the pressure drop over the valve should be at least 10% of the supply pressure or 2.5 mbar whichever is the greatest.

Flow rate adjustment (see fig. 10. and fig. 11.)

1. Remove the cap from top of the coil by loosening both screws.
2. Place a wrench on the adjustment hexagon nut.
3. Turn wrench counter-clockwise to increase or clockwise to decrease the flow rate .
4. Replace cap on top of the coil.

Step pressure adjustment (see fig. 12.)

1. Remove the cap from top of the coil by loosening both screws.
2. Place a screw driver in the slot of adjustment screw which is situated in center of the valve.
3. Turn screw driver counter-clockwise to increase or clockwise to decrease step pressure.
4. Replace cap on top of the coil.

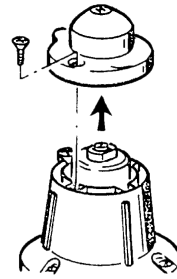

Fig. 10.

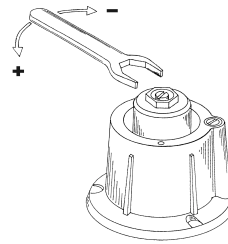

Fig. 11.

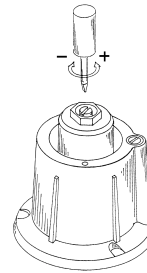

Fig. 12.

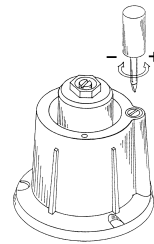

Fig. 13.

Opening speed adjustment (see fig. 13.)

Opening speed is factory set at customer settings, the adjustment screw is sealed.

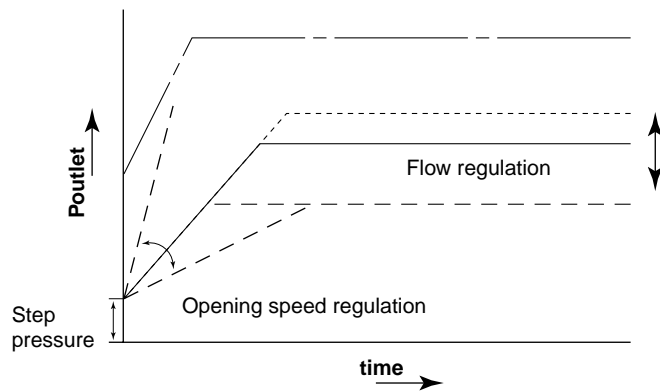

Fig. 14. Characterized opening.

Adjustment outlet pressure

- Disconnect pressure feedback connection (if applicable)
- Energize both electric operators in order to have gas input to burner.
- Check gas input to the appliance using a clocking gas meter or alternatively a pressure gauge connected to the outlet pressure tap.
- Remove pressure regulator cap screw to expose pressure regulator adjustment screw.
- Slowly turn adjustment screw with a small screw driver until the burner pressure required is recorded on the pressure gauge. Turn adjustment screw clockwise to increase or counter-clockwise to decrease gas pressure to the burner.
- For non-regulating mode (LP gas) turn adjustment screw clockwise until it stops.
- Replace pressure regulator cap screw.
- Connect pressure feedback connection (if applicable).

Pressure tap points

The VR400/VR800 series has a number of connections points for measuring pressure, mounting a pressure switch, or IP applications.

The following pressures can be measured:

1. Inlet pressure
2. Interim pressure (pressure between the two shut-off valves)
3. Outlet pressure

The corresponding numbers can be found on the sides of the valve.

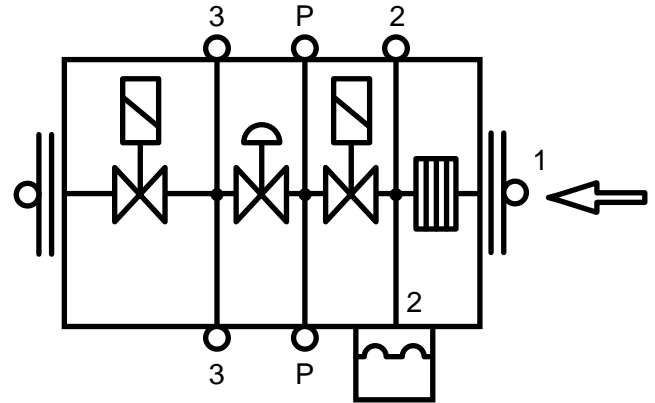

Fig. 15. Pressure tap points

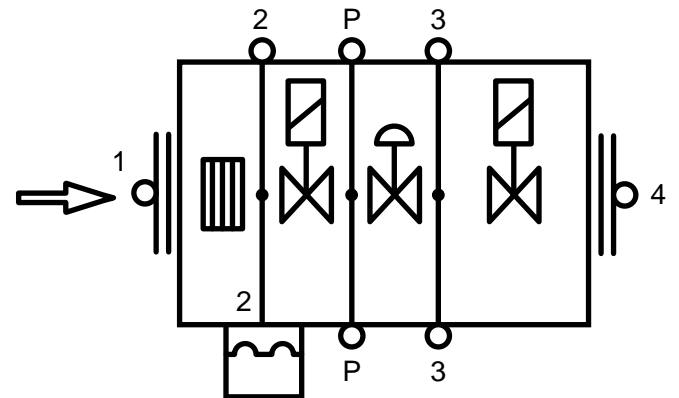

Fig. 16. Pressure tap points

Final checkout of the installation

Set the appliance in operation after any adjustment and observe several complete cycles to ensure that all burner components function correctly.

CONSTRUCTION AND WORKING PRINCIPLES

Servo pressure regulation working.

The VR400/VR800 series servo regulated combination gas valves are 2 x class A fail safe shut-off valves. The valve is opened by energizing the direct ON/OFF operators. Each operator consists of a coil and a stop sleeve assy. Inside the stop sleeve assy is a plunger which is connected to a rubber valve and which is able to move up and down and thus opening or closing the valve.

The plunger is coated with an anti friction material. Flow regulation is done by adjustable plunger stroke. A strainer made out of AISI303 is incorporated between inlet flange and main body. The valve closing spring are made of AISI302.

Seals and gaskets are manufactured out of hydrocarbon resistant NBR according to DIN 3535 and EN 291

The VR400/VR800 series features the positive servo system, i.e. the regulating valve is closed by spring pressure in the normal shut down position and can only be opened when gas pressure is sufficient to overcome the spring force. This valuable built in safety feature ensures the regulating valve will automatically close in the event of power or gas supply failure. The heart of the system is the servo pressure regulator which consists of a pressure relief valve integrated in a regulator diaphragm which is fitted above and controls the regulating valve.

When both operators are energized, inlet gas flows through the servo orifice into the servo system and into the regulator. This servo gas moves the regulating diaphragm upwards enough to open the regulating valve. As soon as the regulating valve has opened, the outlet pressure generated by the VR400/VR800 series will be sensed by the regulator diaphragm via the feedback channel.

When the force operated by the pressure is greater than that preset by the adjustment screw, the regulator valve opens relieving some of the working pressure. This reduces the force against the regulating valve spring allowing the regulating valve to close proportionately. Thus the regulating valve limits the outlet (or burner) pressure to the preset level.

As a result, outlet pressure is continuously maintained by comparing it to the preset pressure and adjusting the position of the regulating valve accordingly. This means that a constant outlet pressure is maintained regardless of inlet pressure variations. At shut down, the small volume of working gas in the regulator and in the diaphragm chamber is dumped into the main outlet chamber.

A reference pressure feedback connection further regulates the outlet pressure by compensating for differences in the air pressure in the combustion chamber and at the valve. If pressure regulation working is not needed, the regulator spring can be blocked by turning the adjustment screw down until it stops or the pressure regulation is removed. In these cases the full servo gas pressure opens the regulating valve as far as the pressure drop allows.

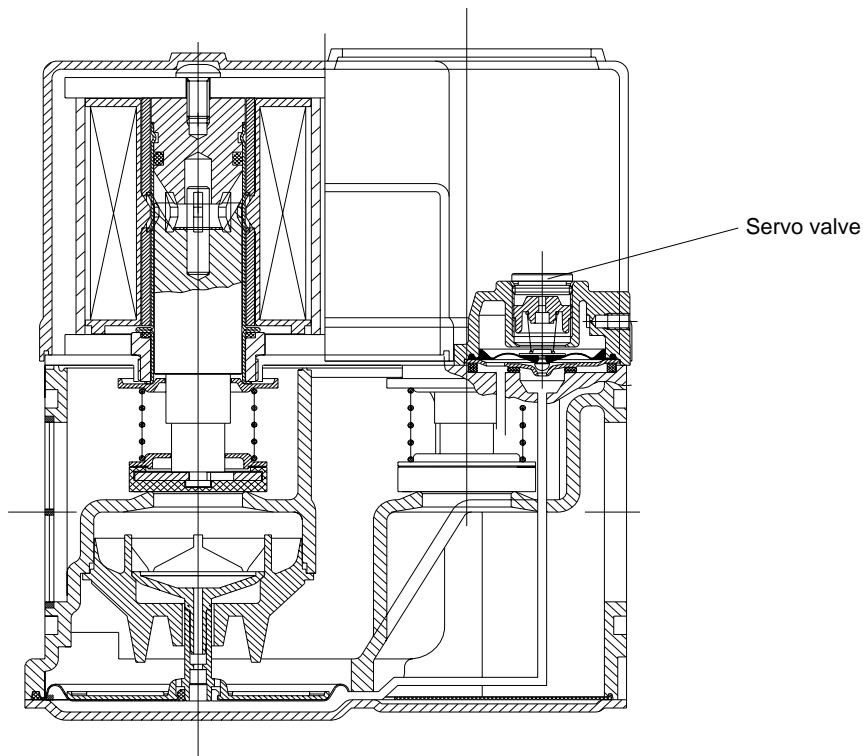

Fig. 17. Servo pressure regulator working

STANDARDS AND APPROVALS

Standards

The VR400/VR800 series servo regulated combination valves have been designed to meet the European Standard EN 126. The safety shut-off valve meets class "A" requirements. According to bending stress the combination valve meets the highest requirements.

Regarding electric safety, the VR400/VR800 series can be used in appliances according to European Standard for a household electrical requirements EN 60335 series and industrial applications.

The VR400/VR800 series also meet all Electro Magnetic Compatibility standards for non-industrial and industrial appliances.

Approvals

The VR400/VR800 series servo regulated class "A" combination valves conform with the following EC-directives:

- Gas Appliance Directive (90/396/EEC)
PIN: 0063AT1198
 - Low Voltage Directive (73/23/EEC)
 - Electro Magnetic Compatibility Directive (89/336/EEC)
- The fact that the VR400/VR800 series are certified to European Standard EN 126 means that this series meets more stringent requirements than laid down in the essential requirements stated in the directives and therefore meets the requirements in all EC and EFTA countries. Details can be found in the Approvals List. The registration number specific for each O.S. number is mentioned on the label of the control.

ORDERING INFORMATION

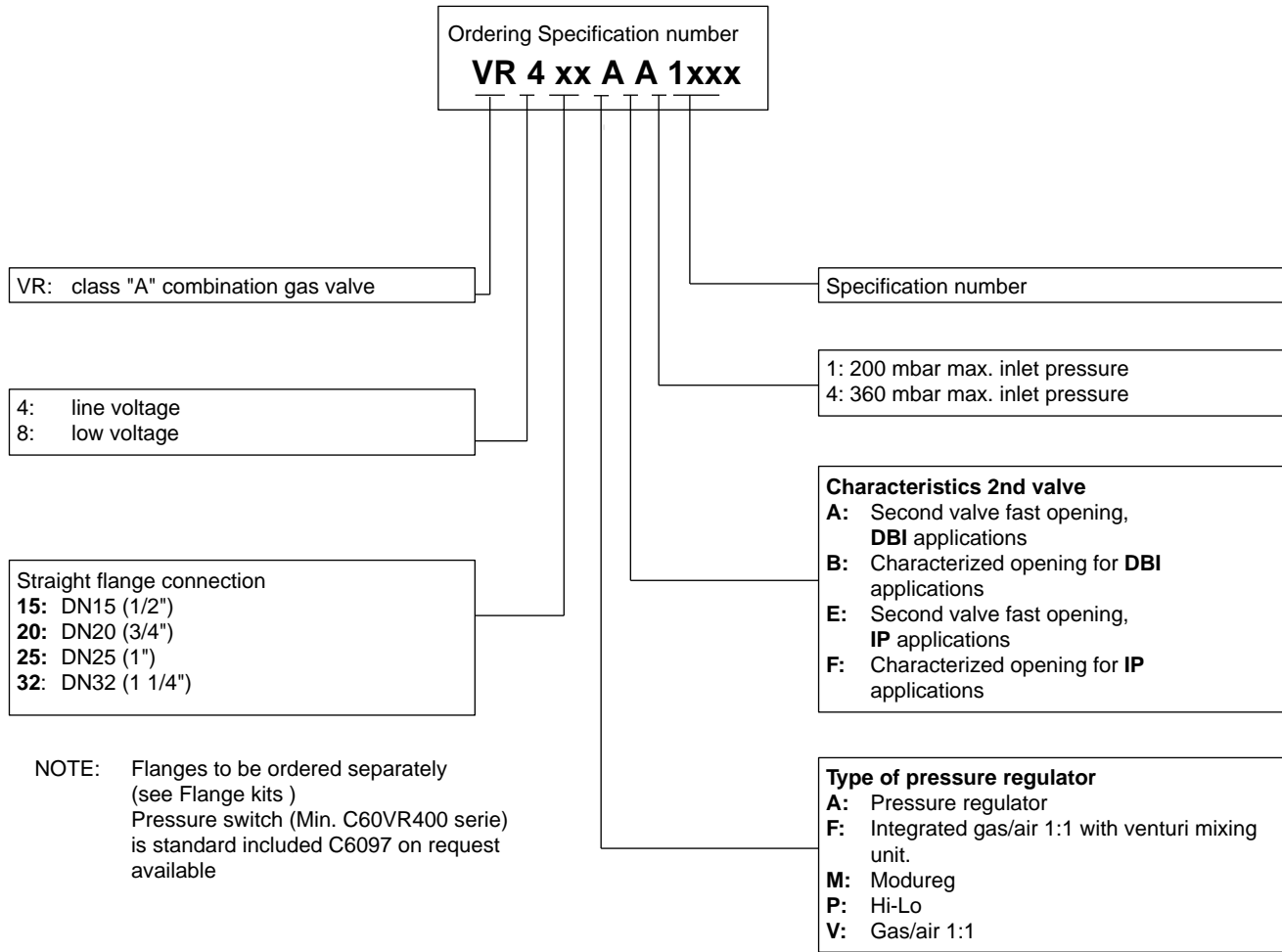

Fig. 18. Ordering information VR400/VR800 series combination valves

How to select your valve

Standard the VR400/VR800 series servo regulated combination valves are equipped with two main valves V1 and V2.

Safety valve V1 is always fast opening/closing.
The second valve (V2) can be either fast or slow (= with flow

regulation and adjustable opening).

At the main body flange connections (8) are provided to mount either pressure switches, a pilot valve, or a VPS + pressure switch.

These additional functionalities can be mounted on various positions of the main body of the VR400.

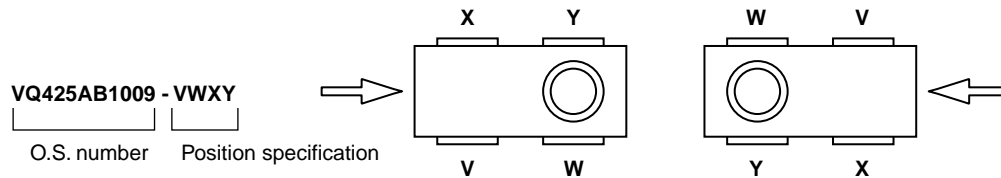

Table 9: VR400 series positions and additional functionalities chart

Type	Code	Positions			
		V	W	X	Y
C60VR40040 (5 ... 40 mbar)	1	•	•	•	•
C60VR40110 (30 ... 110 mbar)	2	•	•	•	•
C60VR40300 (100 ...300 mbar)	3	•	•	•	•
A4021A + C6058A (wired)	4		•		•

Use the 4 digits behind the OS number to specify which option you need in which position.

Example:

With a 5 ... 40 mbar pressure switch on position V, the full O.S. number will be VR425AB1009-1000.

If you do not want any additional option the O.S. number will be VR425AB1009-0000

REPLACEMENTS

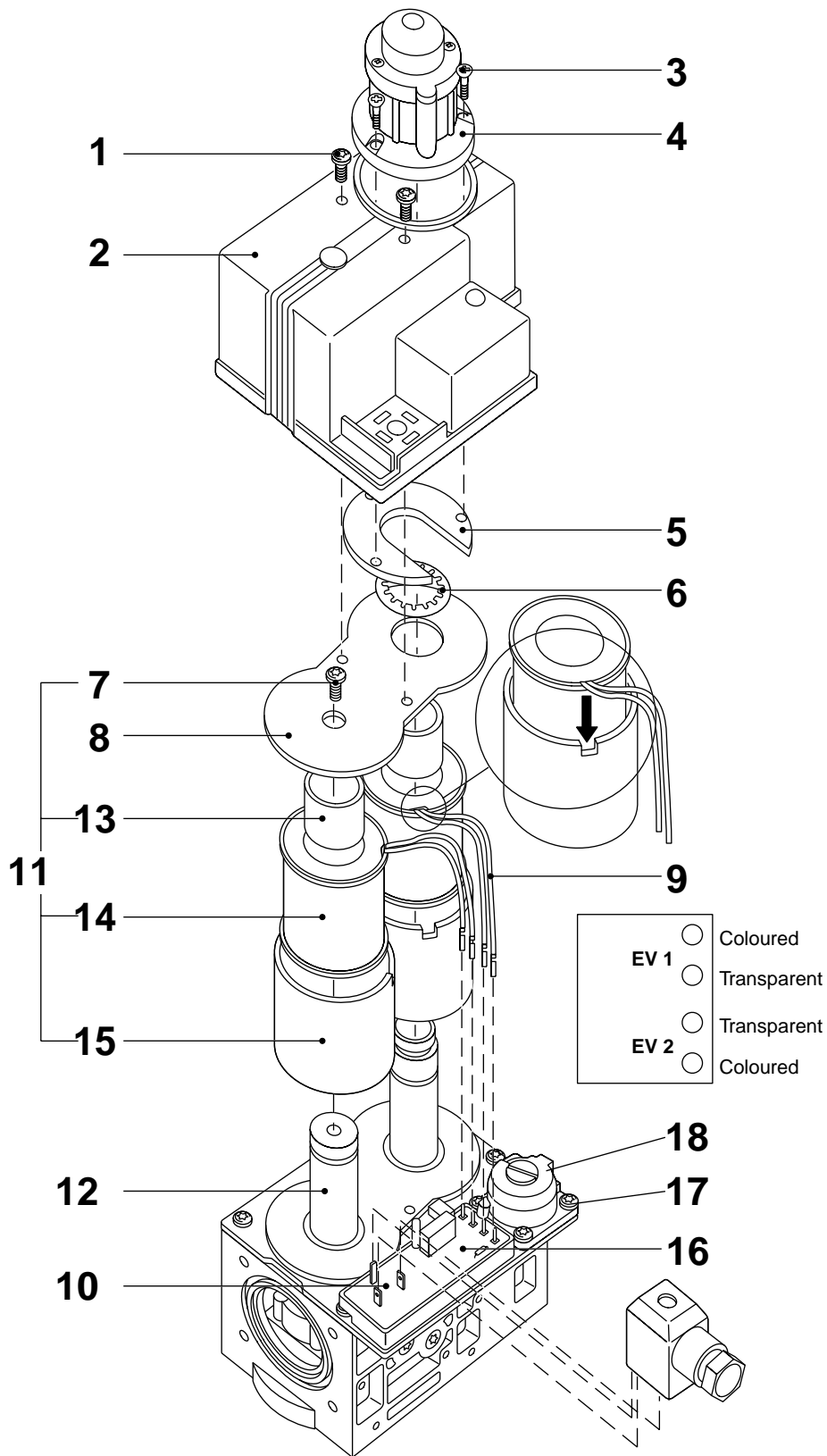

Fig. 19. Exploded view of the VR400/VR800 series

Replacement of coils (see fig. 19.)

WARNING

Disconnect power supply before

1. Remove screws (1) on top of cover.
2. Lift cover (2).
3. Remove three screws (3) hydraulic unit (4).
4. Lift hydraulic unit (4).
5. Remove mounting bracket (5).
6. Remove blade spring (6).
7. Loosen and remove screw first operator (7).
8. Remove top plate (8).
9. Disconnect leads coils (9) from circuit board (10).
10. Lift coil assy (11) from operator (12).
11. Remove flux tube (13) from coil assy.
12. Remove coil (14) from tube (15).
13. Place new coil in tube with leads on top and in slot of the tube.
14. Replace flux tube into coil assy from top.
15. Place assy on operator with leads on top and in slot of operator.
16. Connect leads.
17. Replace top plate and fasten it with screw.
18. Replace blade spring.
19. Replace mounting bracket.
20. Replace cap or hydraulic unit and fasten it with screws.
21. Check if seal cover is mounted correctly and correct if needed.
22. Replace cover and fasten it with screws.

Remark: for fast opening versions, operations 3 and 4 are not applicable.

Replacement of rectifier board (see fig. 19.)

WARNING

Disconnect power supply before

1. Remove screws (1) on top of cover.
2. Lift cover (2).
3. Disconnect leads coils (9) from circuit board (10).
4. remove screw (16) from printed circuit board.
5. Lift printed circuit board.
6. Place new printed circuit board.
7. Replace and fasten screw in printed circuit board.
8. Connect leads.
9. Check if seal cover is mounted correctly and correct if needed.
10. Replace cover and fasten screws.

Replacement of hydraulic slow open unit (see fig. 19.)

WARNING

Disconnect power supply before

1. Remove screws (1) on top of cover.
2. Lift cover (2).
3. Remove three screws (3) from hydraulic unit (4).
4. Lift hydraulic unit (4).
5. Place new hydraulic unit and fasten it with screws.
6. Check if seal cover is mounted correctly and correct if needed.
7. Replace cover and fasten it with screws.

Replacement of pressure regulator (see fig. 19.)

WARNING

Disconnect power supply before

1. Disconnect pressure feedback connection (if present).
2. Loosen and remove screws (17) from regulator (18).
3. Lift regulator (18).
4. Remove rubber gasket (19).
5. Place new gasket.
6. Place new regulator and fasten it with screws.
7. Reconnect pressure feedback connection.
8. Reconnect pressure and power supply.
9. Energize valve.
10. Check for leakage.

REPLACEMENT PARTS AND ACCESSORIES

IMPORTANT

When ordering replacement coils include the complete valve O.S. number, in order to provide the coil with proper product identification sticker.



WARNING

- Take care that only qualified persons carry out the installation of parts, accessories, and add on components.
- Follow the installation instructions included in the package.
- Check that the selected part, accessory or add on component is the correct one for the application in question.
- Replace the old gaskets with the new ones supplied in the package and check for leakage when the supply is switched on again.
- After installation and/or replacement has been completed, a gas leak test must be carried out.
- Also check the gas valve for satisfactory operation after fitting accessories.

Table 10: Coils for VR400/VR800 series

Model		Order number	Rated Voltage (Vac)	200 mbar	Packing qty	100 mbar
DN15 DN20	V1	BBE20020	230	•	1	
		BBE20021	110	•	1	
		BBE20022	24	•	1	
	V2	BBE20020	230	•	1	
		BBE20021	110	•	1	
		BBE20022	24	•	1	
DN25	V1	BBE20025	230	•	1	
		BBE20026	110	•	1	
		BBE20027	24	•	1	
	V2	BBE20025	230	•	1	
		BBE20026	110	•	1	
		BBE20027	24	•	1	
DN32	V1	BBE20025	230		1	•
		BBE20026	110		1	•
		BBE20027	24		1	•
	V2	BBE20025	230		1	•
		BBE20026	110		1	•
		BBE20027	24		1	•

Table 11: Rectifier boards for VR400/VR800 series

Model	Order number	Rated Voltage (Vac)	Packing qty
IP application DN15 DN20 DN25 DN32	CSE20026	230	1
	CSE20026	110	1
	CSE20028	24	1
DBI application DN15 DN20 DN25 DN32	CSE20025	230	1
	CSE20025	110	1
	CSE20027	24	1

Table 12: Slow open units

Model	Order number
DN20	GFO50001
DN25	
DN32	

Table 13: Regulators

Regulator type	Range	O.S.number
Standard regulator	2.5 ... 20	V53306E 1002
	3 ... 37	V5306E 1143
	10 ... 60	V5306E 1119
High- Low regulator 230V 50Hz	3... 20	
	4 ... 37	
	8 ... 50	
Modureg 165 or 250 mA	1.5... 20	
	3 ... 37	
	8 ... 50	

Honeywell

**Home and Building Control
Combustion Control Center Europe**

Honeywell BV

Phileas Foggstraat 7

7821 AJ Emmen

The Netherlands

Tel.: +31 (-)591 695911

Fax: +31 (-) 591 695200

<http://europe.hbc.honeywell.com>